

OSCO is Valve Gating



- **Air or Hydraulic Drive**
- **Sequential Molding**
- **Co-injection**
- **Structural Foam**
- **Gas Assist**
- **Stack Molds**
- **Standard, Hybrid and Custom Systems**

OSCO[®] *inc.*
RUNNERLESS MOLDING SYSTEMS

Ask for your
complete
catalog
on CD



SCV

Single Cavity Valve Gate

Simplicity Through Thoughtful Engineering

Simplicity

- Simplified Installation
- Simplified Adjustments
- Simplified Operation

Performance

- Gates up to .312
- Shaft Driven
- One-To-One Ratio

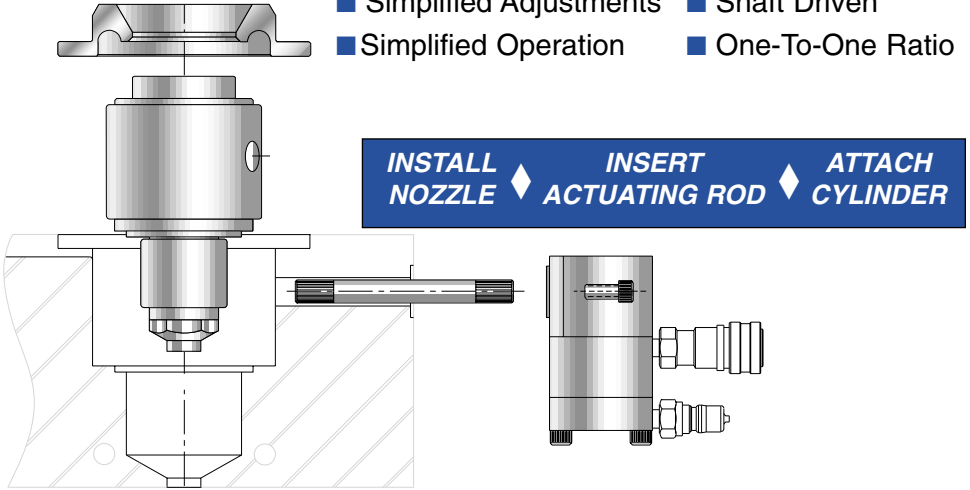

Setting The Valve Pin Is As Easy As:

1. Energize Cylinder
2. Loosen S.H.S.C.
3. Pivot Cylinder to Achieve Best Possible Gate Cosmetics

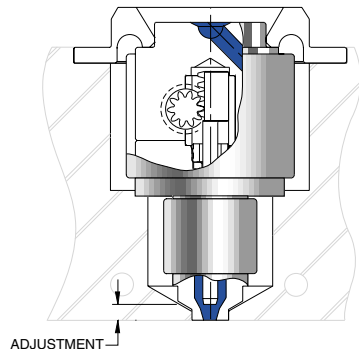
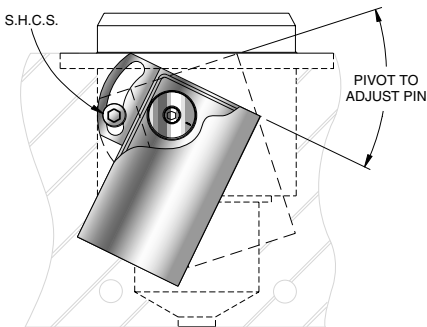

E-mail: sales@oscosystems.com

VGN Valve Gate System

The Pre-eminent Valve Gate System On The Market Today

*Hydraulic or Pneumatic
Valve Gating*

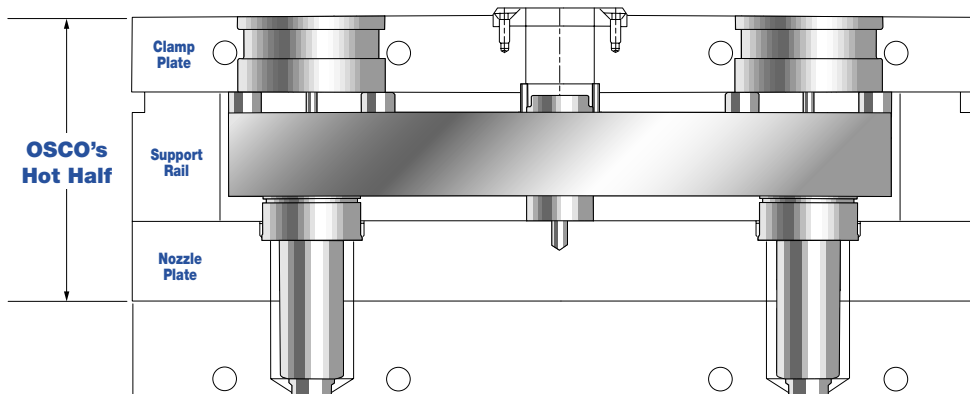

- Self-contained cylinder floats with manifold's thermal expansion
- Valve pin guide maintains concentricity with gate, extending gate life
- Valve pin is installed or removed with the mold fully assembled

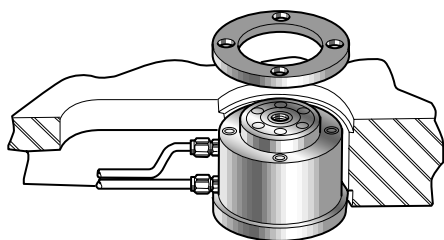

"Floating" Cylinder

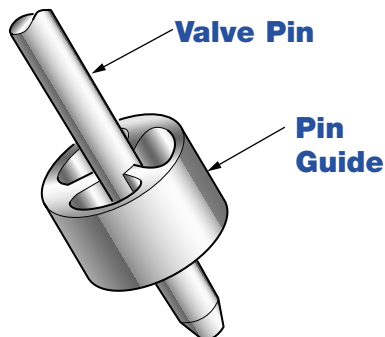

Call Us Direct @ 1-800-499-OSCO

DSV

Large Part Molding

Direct Feed Or Manifold Application

**NO VALVE PIN
THROUGH MANIFOLD**

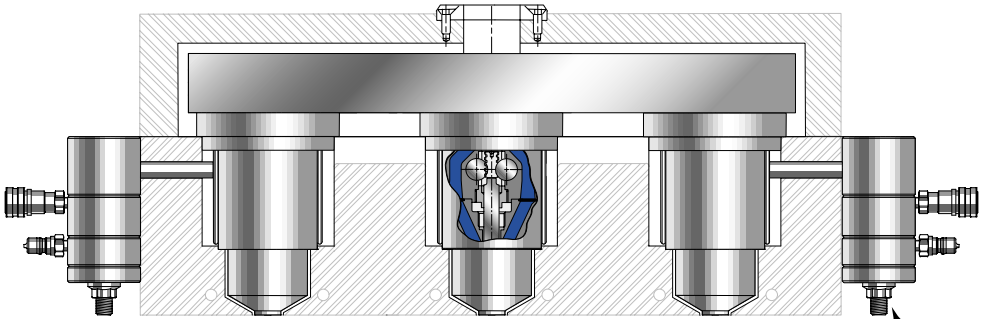

Valve Pin Adjuster

**NO CYLINDER
MACHINING IN T.C.P.**

Cylinder Outside Mold

- Dramatically reduces machining and installation time
- Enables press-side setting and adjusting of valve pin

Self-Contained Valve Pin

- Allows placement of nozzle directly in-line with the machine nozzle with or without a manifold
- Simplifies valve gating by eliminating valve pin travel through the manifold

IDEAL FOR STACK MOLDS

VGS Valve Gate Sequencer

Available in Air or Hydraulic

**A QUIET, VERSATILE,
LOW-ENERGY
VALVE GATE SEQUENCER
FOR TODAY'S HI-TECH
MOLDING**



Touch Screen Controller

- Mold storage
- Standard Time-Based Switching
- Optional linear position switching
- Optional cavity pressure switching



Mobile Valve Gate Sequencer

- 120 volt AC power
- Compact – small foot print
- Super quiet
- Over 50% energy savings compared with other units

E-mail: sales@oscosystems.com